

# Comparing Experts and Novices in Solving Electrical Circuit Problems with the Help of Eye-Tracking

David Rosengrant, Colin Thomson, Taha Mzoughi

*Kennesaw State University, Department of Biology and Physics,  
1000 Chastain Road, MD 1202, LB, Bldg. 17, Rm. 240, Kennesaw, GA 30144-5591*

**Abstract.** In order to help introductory physics students understand and learn to solve problems with circuits, we must first understand how they differ from experts. This preliminary study focuses on problem-solving dealing with electrical circuits. We investigate difficulties novices have with circuits and compare their work with those of experts. We incorporate the use of an eye-tracker to investigate any possible differences or similarities on how experts and novices solve electrical circuit problems. Our results show similarities in gaze patterns among all subjects on the components of the circuit. We further found that experts would look back at the circuit while solving the problem but not the novices. We also found differences in how they solve the problems. For example, experts simplified circuits when appropriate as opposed to novices who did not. They also had difficulties identifying when resistors are in parallel or in series and how to combine them.

**Keywords:** eye tracking, expert-novice differences, problem solving, electrical circuits, multiple representations.

**PACS:** 07.50.Ek, 01.40.-d

## INTRODUCTION

There is a broad gap between the abilities and skill levels of experts and novices in all fields [1], especially in physics [2-4]. The gaps can include how they understand content, learn new material and solve problems [5]. As we focus on more specific areas in physics, we find more specific gaps between the two groups which lead to student difficulties. Previous research has shown us some student difficulties [6-10]. This preliminary study focuses specifically on the difficulties with electrical circuits. This investigation of expert novice differences includes data from an eye tracker. This data allows us to determine what the subjects focus on while solving problems and answering conceptual questions [11] and allows us to identify subtle patterns and behaviors.

## THEORETICAL FOUNDATION

According to previous studies, experts tend to finish problems faster, with more accurate solutions, and are more likely to approach problems systematically [5]. Experts tend to use a “forward inference technique:” they use the concepts in the problem to help devise a plan to solve it. They tend to focus on the underlying concepts of problems. Novices

focus on surface features while they solve problems [2]. They use a “backward inference technique,” [5] they focus on what they need in their answer, find a matching formula and then work backwards towards a solution. Novices’ difficulties with solving problems do not end with their search technique. They typically have difficulties finding alternative strategies when “stuck,” evaluating their work, [4] and using tools like representations as effectively as experts [12-14].

These differences extend into all fields of physics. In DC circuits the differences between experts and novices are more specific. For example, current is a major conceptual challenge to novices. They tend to believe that current gets “consumed” when moving through a circuit and that parallel branches split current equally throughout the branches regardless of the arrangement of the resistors [10]. Novices also believe that the battery is a constant source of current [6]. Their difficulties with current are compounded by the fact that they interchange the ideas of “current” and “voltage” [9]. They believe that circuits are a system of pipes that allow a fluid called electricity to flow through them [15]. These difficulties become even more noticeable when one incorporates series and parallel sections of circuits. Even identifying what components of a circuit are in parallel or in series are a challenge for many students [7].

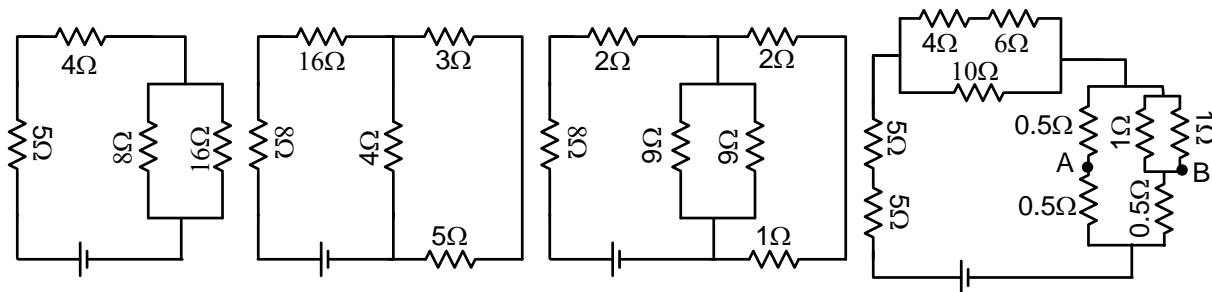

**FIGURE 1.** 4 circuits given to students

Recently, computer simulations have been used to increase students understanding of circuits. Students who learned about circuits on simulated equipment outperformed students who learned on actual circuits [16]. Not only do students learn better with simulated equipment, they also favor learning with simulations [17] and they are able to develop assessments based upon observations from the simulations [18].

## METHODS

The study was conducted in the second semester of a 44 student two-semester introductory algebra based physics course. Students were typically Biology and Health and Exercise Science majors. The students in this course studied electro-statics which included capacitance networks, circuits, magnetism, waves and optics. Students studied electrical circuits and how to construct/simplify them with simulations as part of lab and pre-lab activities. The course was taught at Kennesaw State University, a suburban university of about 21,500 students.

Eleven subjects participated in this study. Nine were students in the above course who we considered novices. The other two were physics faculty members at the university who we consider the experts. One was more advanced since he taught an upper level undergraduate electronics course. Each subject participated in one session that lasted about 45 minutes. The novices received extra credit and were offered free physics tutoring as compensation.

We gave the subjects a series of questions based on 4 circuits of increasing complexity (Fig. 1). Some of the questions required only an auditory response while others may have required them to write out their work using a graphic tablet monitor. They wore a head mounted eye-tracker while they answered the questions. The eye tracker was an Applied Science Laboratories Model 6000 Mobile Control Unit that included an Applied Science Laboratories head-mounted optics unit with scene camera. The eye tracker provided a video showing us what the subjects focused on while they answered our questions. We also audio and video taped each session. Our data

came from a series of questions about each of the circuits. For circuits 1 through 3 we asked the subjects to calculate the net resistance of the circuit. We asked the subjects questions comparing current flow through different resistors in circuits 1 and 2 as well as questions about the potential drop across several of the resistors. We asked a series of questions involving scenarios that would create short circuits in circuit 2 and scenarios about the effects of adding resistors for circuit 3. Finally, we asked one question in circuit 4 involving the potential difference between points A and B. In each situation, the subjects were given a space for their work and a calculator to use if needed.

## FINDINGS

Our data shows several distinct differences between the novices and the experts. Some of these differences support previous research whereas others are new. There were differences in how the groups solved the problems, what they had difficulty with and what they focused on.

One of the most common difficulties novices had when calculating the net resistance was that they were confusing the rules for combining resistors in parallel and in series. For example, in circuit 1, instead of adding the  $8\ \Omega$  and the  $16\ \Omega$  as  $1/8$  and  $1/16$  equals  $1/\text{the net resistance}$ , they added them as if they were in series:  $8 + 16 = \text{net resistance}$ .

Our data also supported reference 7 when subjects had difficulties understanding what components of the circuit were in parallel and in series. Six of the nine novices had difficulties in simply identifying this concept. We saw much difficulty circuit 2 (Refer to Fig. 1). Subjects thought that the  $3\ \Omega$  and the  $5\ \Omega$  resistor were in parallel. Similarly, some thought that just the  $4\ \Omega$  and the  $8\ \Omega$  were in parallel. No subjects had difficulty identifying the  $8\ \Omega$  and the  $16\ \Omega$  resistors in circuit 1 as being in parallel, which we would label as a “textbook” parallel circuit. Another issue the subjects exhibited in identifying series and parallel components was their apprehension in believing that one could have more than two resistors in parallel.

A possible way to combat this difficulty is to simplify the circuit. The novices were reluctant to do this. Only two novices simplified a circuit. Both novices only redrew one circuit out of all of them. Instead of redrawing the circuits, it was common for the novices to make marks on the circuits we gave them, either crossing out or linking resistors. However, both experts completely redrew at least one of the circuits. The first expert (who is not as strong in electrical circuits) redrew two circuits and redrew them multiple times. The second expert (who teaches electrical circuits) redrew only the third circuit one time. What is also important to note is that when the two novices redrew the circuit, neither of the two completely labeled the resistors. Both experts included the value of each resistor in every circuit they redrew.

Novices also differed from the experts when working with Ohms law. The novices were much more reliant on using Ohms law to answer questions compared to the experts. This was evident through comments like “let me look back at Ohm’s law” or “according to Ohm’s law.” This also led to some other conceptual difficulties. Novices had difficulty relating current and resistance in two different ways. Some novices believed that there was a direct relationship between the two. The first idea was that the higher the resistance the higher the current through that resistor. Their logic was that one needs to have a higher current in order to get past the larger resistance. The second idea was that the lower the resistance the higher the current. This is correct if the potential difference is the same, however the novices were applying this on a resistor-by-resistor basis.

The same difficulties arose when combining voltage and resistance: the higher the resistance the higher the voltage drop across the resistor regardless of the arrangement. On average all the novices exhibited less of an understanding of potential difference across the resistors than about the current moving through the resistors.

Other responses from the novices show support for reference 10. For example, three novices stated that current will divide up equally between the two paths if one has a portion of a circuit with two resistors (regardless of value) in parallel. One subject also specifically stated that “as current flows through the resistors it gets used up by them.”

The eye-tracker data reveals some interesting trends. As previously shown [4], experts evaluate their work when they are solving a problem. In our case, the experts would constantly turn their attention back and forth between their work and the circuit we gave them (or the circuit they redrew). Novices tended not to do this. They would focus their attention back and forth within their work, but were far less likely to turn their attention back to the circuit while solving the problem.

When they finished their work, experts would look over their entire work whereas the novices did not.

The eye-tracking data also showed that both the novices and the experts tended to look back and forth between pairs of resistors. These paired resistors were those that you would combine either in series or in parallel. For example, in circuit 2, the subjects would look between resistors 8 and 16 and then again at resistors 3 and 5 as shown in Figure 2. Though both the novices and the experts initially looked at the resistors in pairs, the experts then moved on to the entire circuit unlike novices who spent more time gazing back and forth between the pairs of resistors.

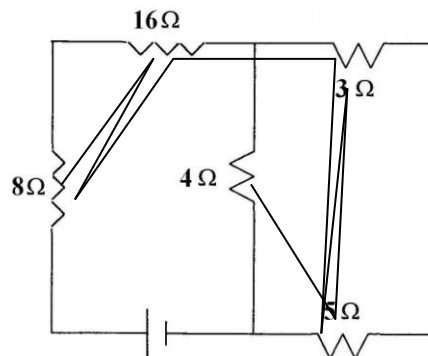

FIGURE 2. Sample gaze path of circuit 2

Another difference between the groups is that the novices followed (shown in Fig.2) the shortest path between the resistors with their eyes. However, the gaze pattern of one of the experts (who taught the undergraduate electronics course) showed something different. His gaze pattern is shown in Fig. 3.

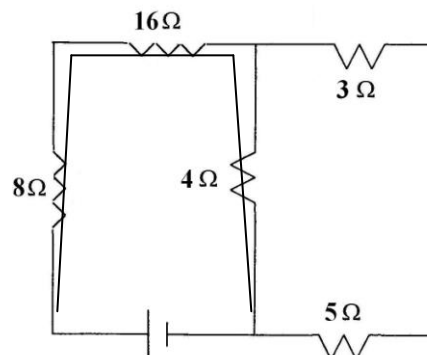

FIGURE 3. Expert partial gaze path of circuit 2

As shown in Fig. 3, the gaze pattern suggests that the expert followed the path of the current. None of the novices exhibited this gaze pattern behavior though they may have discussed the process of how current moves through one resistor before the other, as in reference 21.

## DISCUSSION

Our findings both reinforce and introduce ideas about expert and novice differences in electrical circuits. Though previous research [22] shows that students have difficulty when adding resistors, we were surprised by the amount of difficulty the students had. Perhaps this is due to the fact that the students confused the rules with the ones used for combining capacitors

A second surprising result from this study is the difference between how the novices and the experts reconstructed circuits, or rather the lack of reconstructing them. The experts' activities of reconstructing circuits reinforces reference 5 about knowing how to use different strategies to solve problems. Thus, if we want our students to develop expert-like problem solving skills, they must learn how to take the time to reconstruct these diagrams.

More work also needs to be done to understand why novices have difficulty identifying parallel and series components of circuits. Future studies on this topic could involve giving students multiple circuits with resistors in various locations and simply have them identify which circuits are identical.

Ohm's law, the cornerstone of most DC circuit problems, also proves questionable to students on many different levels. Ohm's law can be used on each individual component of a circuit. However, that does not mean that the rest of the circuit can be ignored as some novices displayed during their sessions.

The supporting eye-tracking data gives additional insight into expert-novice differences. The experts gaze patterns show that even when they solve basic problems they must still, either consciously or unconsciously look back over the circuit and their work. This suggests that regardless of the level of difficulty experts must reflect upon their work while solving the problem. Furthermore, the experts tended to look at the entire circuit and how current flows through the circuit as opposed to looking at it as a series of components connected together.

Finally, we must address some of the limitations of our study. First, our data pool was only from those students who volunteered because they needed extra credit, thus this limits variation in our novice sample. The eye-tracker itself, if not calibrated correctly, can provide questionable data, which is why we were forced to reduce our sample size. Most of the eye tracking data obtained was usable but not all. One novice kept moving the eye piece while others had trouble with calibration giving us eye-tracking data from six of the nine novices.

## ACKNOWLEDGMENTS

We would like to thank Dr. Jeff Pelz from the Rochester Institute of Technology for his assistance with the eye-tracking equipment.

## REFERENCES

1. W. Chase and H. Simon, *Cognitive Psychology* **4**, 55-81 (1973).
2. M.T.H. Chi, P.J. Feltovich, and R. Glaser, *Cognitive Science* **5**, 121-152 (1981).
3. J. Larkin et al., *Science* **208**, 1335-1342 (1980).
4. W. Gerace, *Proceedings of the 2001 PERC* (2001).
5. J. Clement, *Proceedings of the Sixteenth Annual Conference of the Cognitive Science Society*, Lawrence Erlbaum, Hillsdale, NJ, 201-206 (1994).
6. P.V. Engelhardt and R.J. Beichner, *Am. J. Phys.* **72**, 98-115 (2004).
7. L.C. McDermott and P.S. Shaffer, *Am. J. Phys.* **60**, 994-1003 (1992).
8. P.S. Shaffer and L.C. McDermott, *Am. J. Phys.* **60**, 1003-1013 (1992).
9. A. Mtioui et al., *Int. J. Sci. Educ.* **18**, 193-212 (1996).
10. R. Duit and C. Rhonek, "Learning and Understanding Key Concepts in Electricity," in *Connecting Research in Physics Education with Teacher Education*, edited by A. Tiberghien, E.L.Jossem, and J. Barojas, The International Commission on Physics Education, 1997, pp. 1-6.
11. A.T. Duchowski, *Eye Tracking Methodology: Theory & Practice*, London, UK: Springer-Verlag, 2003.
12. P.B. Kohl and N.D. Finkelstein, *Phys. Rev. Sp. T., Phys. Ed. Res.* **4**, 010111 (2008).
13. D. Rosengrant, E. Etkina and A. Van Heuvelen, "An Overview of Recent Research on Multiple Representations," in *Proceedings of the 2006 PERC*, McCullough, Heron, & Hsu, eds., 149-152 (AIP, 2006).
14. D. Rosengrant et al, *Phys. Rev. Sp. T., Phys. Ed. Res.* **5**, 010108 (2009).
15. S. Johsua, *European Journal of Science Education* **6**, 271-275 (1984).
16. N.D. Finkelstein et al., *Phys. Rev. Sp. T., Phys. Ed. Res.* **1**, 010103 (2005).
17. M. Ronen and M. Eliahu, *Journal of Computer Assisted Learning* **16**, 14-26 (2001).
18. C.V. de Olde and T. de Jong, *Int. J. Sci. Educ.* **26**, 859-873 (2004).
19. Physics Education Technology project, <http://phet.colorado.edu>
20. W. Christian and M. Belloni, *Physlets: Teaching Physics with Interactive Curricular Material*, Addison Wesley, 2001.
21. J. Marshall, *Electronic Journal of Science Education* **12**, 1-22 (2008).
22. R. Knight, *Five Easy Lessons: Strategies for Successful Physics Teaching*, Addison-Wesley, 2003.